

MODEL TC POWER TAKE-OFF TC113



QUALITY IS STANDARD

- EXTERNAL ADJUSTMENT OF LEVER ENGAGEMENT TRAVEL
- SPRING LOADED CLUTCH
- SEALED FOR LIFE PILOT BEARING
- EASE OF ADJUSTING LEVER TRAVEL
- ADJUSTMENT NOT REQUIRED
- LESS MAINTENANCE

SPECIFICATIONS - TC113

Model Number	SAE HSG.	Dimension "A" mm (in)	Dimension "B" mm (in)	Dimension "C" mm (in)	Dimension "D" mm (in)	Dimension "E" mm (in)	Maximum Safe Speed
TC113P302	3	52 (2.047)	97.6 (3.84)	234.8 (9.12)	52 (2.047)	52 (2.047)	3400
TC113P303	3	62 (2.441)		62 (2.441)	62 (2.441)	62 (2.441)	

LOAD CLASSIFICATIONS BASED UPON AGMA LOAD CHARACTERISTICS

PRIME MOVER	DURATION OF SERVICE	DRIVEN MACHINE LOAD CLASSIFICATIONS		
		UNIFORM	MODERATE SHOCK	HEAVY SHOCK
Electric motor	Up to 3 hours per day	1.00	1.25	1.50
	3-10 hours per day	1.00	1.25	1.75
	Over 10 hours per day	1.25	1.50	2.00
Multi-cylinder internal combustion engine	Up to 3 hours per day	1.00	1.25	1.75
	3-10 hours per day	1.25	1.50	2.00
	Over 10 hours per day	1.50	1.75	2.25
Multi-cylinder internal combustion engine with high torque rise	Up to 3 hours per day	1.50	1.75	2.25
	3-10 hours per day	1.75	2.00	2.50
	Over 10 hours per day	2.00	2.25	2.75
Single cylinder internal combustion engine	Up to 3 hours per day	1.25	1.50	2.00
	3-10 hours per day	1.50	1.75	2.25
	Over 10 hours per day	1.75	2.00	2.50

All clutch engagements to be with prime mover below 1000 RPM. High inertia loads may require use of larger clutch. Contact Twin Disc application engineering department for assistance.

TO CALCULATE APPLICATION TORQUE:

$$\frac{5252 \times \text{HP}}{\text{Engine RPM}} = \text{Torque}$$

$$\text{Torque} \times \text{Load Factor} = \text{Application Torque}$$

Use load factor from chart at left

Specifications subject to change without prior notice in the interest of continual product improvement. Contact your local Twin Disc representative for engineering specifications.



TC113

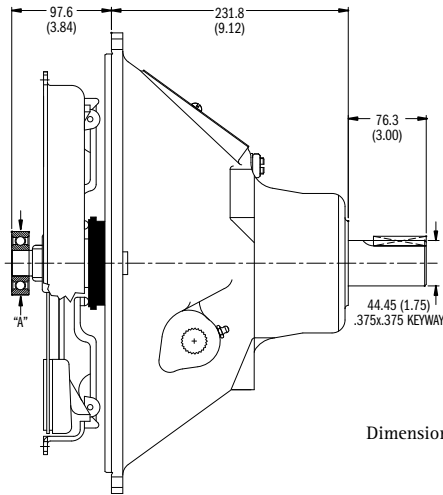

Dimensions are in mm (inches)

For nearly a century, we've been putting horsepower to work by designing, engineering and manufacturing rugged-duty industrial products. Our products and our reputation are bolted to the most renowned engine manufacturers and equipment OEMs in the world. Our mission is to make your machines and vehicles more productive, more durable, more operator-friendly, more cost-effective. From design and installation consultation through after-sale support, Twin Disc and its distributors are committed to your business. No one knows more about managing horsepower in more ways than Twin Disc.

**TRANSMISSIONS • CLUTCHES • PTOS
PUMP DRIVES • TORQUE CONVERTERS
GEARBOXES • HYDRAULIC PTO PRODUCTS**

TC113 – ALLOWABLE SIDE LOAD, KG (LBS)

PTO MODEL	RPM	X DISTANCE, mm (in) – see sketch		
		25.4 (1.0)	50.8 (2.0)	76.2 (3.0)
TC113	1000	871 (1921)	710 (1565)	620 (1367)
	2000	772 (1701)	612 (1350)	535 (1179)
	3000	679 (1496)	538 (1187)	470 (1037)

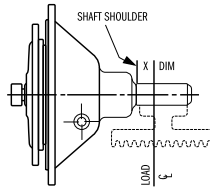

The following general formula should be used for determining the actual applied load: $L = \frac{126,000 \times \text{HP}}{N \times D} \times F \times \text{LF}$

WHERE L = Actual Applied Load (lbs)
 N = Shaft Speed (RPM)
 D = Pitch Diameter (in) of Sheave, etc.
 F = Load Factor
 1.0 for Chain or Gear Drive, 1.5 for Timing Belts, 2.5 for All V Belts, 3.5 for Flat Belts
 LF = 2.1 for Reciprocating Compressors and other Severe Shock Drives and 1.8 for Large Inertia Type Drives (i.e. crushers, chippers, planers, etc.)

Compound Drives and Power Engaged Power Take-Off applications must have written factory review.

Twin Disc, Incorporated reminds users of these products that their safe operation depends on use in compliance with engineering information provided in our catalog. Users are also reminded that safe operation depends on proper installation, operation and routine maintenance and inspection under prevailing conditions. It is the responsibility of users (and not Twin Disc, Incorporated) to provide and install guards or safety devices which may be required by recognized safety standards or by the Occupational Safety and Health Act of 1970 and its subsequent provisions.

United States of America • Australia • Belgium • France • Italy • Singapore • Switzerland



**Twin Disc, Incorporated
 Racine, Wisconsin 53403 USA
 Phone +1-262-638-4000
 Fax +1-262-638-4482
 www.twindisc.com**

TD-Bulletin-TC113
 © 2007, Twin Disc, Incorporated
 Printed in the USA - 04/2007